



CIGS SOLAR MODULES

Q.SMART & SL SERIES

Installation and operation manual for

Q.SMART, Q.SMART UF, Q.SMART UF L, SL1, SL1-F, SL2

Valid for Europe

Q.CELLS

1	INTRODUCTION	PAGE 3
2	PRODUCT DESCRIPTION	PAGE 4
3	SAFETY INSTRUCTIONS	PAGE 5
3.1	TRANSPORT AND STORAGE	PAGE 5
4	AREA OF USAGE AND INSTALLATION LOCATION	PAGE 6
5	LAYOUT, MOUNTING AND INSTALLATION	PAGE 7
5.1	MOUNTING LAYOUTS	PAGE 8
5.2	MECHANICAL MOUNTING - UNFRAMED MODULES	PAGE 10
5.3	MECHANICAL MOUNTING - FRAMED MODULES	PAGE 11
5.4	ELECTRICAL LAYOUT	PAGE 12
5.5	GROUNDING	PAGE 13
5.5	ELECTRICAL INSTALLATION	PAGE 14
6	TROUBLESHOOTING	PAGE 14
7	CLEANING AND MAINTENANCE	PAGE 15
8	DECOMMISSIONING AND RECYCLING	PAGE 15
9	CONTACT	PAGE 16

DOCUMENT REVISION 4.0

This document applies for Europe for the following as of December 2010:

- Q.SMART (SL1-F), Q.SMART UF (SL1), Q.SMART UF L (SL2) of product revision G1.0 and higher, and replaces all past revisions of the installation and operating manual of those modules.

Technical parameters and design are subject to change. The data sheets and customer information valid at the point in time when the relevant module was manufactured apply for the carrying out of installation, mounting or maintenance work on the solar modules.

1 INTRODUCTION

Q-Cells CIGS solar modules allow you to directly transform the unlimited energy provided by the sun into environmentally friendly electrical energy.

In order to be able to completely exploit the full performance capacity of the Q-Cells solar modules, please read the following instructions carefully. Failure to observe them may result in bodily injury and property damage.

This manual only applies for installations in Europe. It provides information on safety precautions to be used during the handling and installation of Q-Cells SE CIGS solar modules along with technical instructions to be followed during installation, mounting, wiring and operation.

Beware of the following module correlation:

- Q.SMART corresponds to SL1-F
- Q.SMART UF corresponds to SL1
- Q.SMART UF L corresponds to SL2.

Installation, operation and maintenance works on a photovoltaic system must be carried out by qualified persons able to carry out the technical procedures described in this manual, i.e. system, installer and maintenance personnel. If you do not possess these qualifications, you may not carry out the work described except for cleaning (Chapter 7).

Information for installers

Ensure that the solar system is set up, expanded, modified and maintained in accordance with the requisite local and federal laws and regulations, as well as with the generally recognized electrical and building codes of the country in which it will be operated.

Hand over the installation and operation manual to the respective operator of the solar system after installation. Inform the operator that these instructions are part of the product and should be kept for the entire useful life of the solar installation.

Information for operators

Keep these instructions safe for the entire life of the module. Particularly observe chapters 6 (troubleshooting) and 7 (cleaning and maintenance).

Please contact your plant supplier for information concerning the formal requirements for solar systems. Please be sure to learn about directives and permit requirements from the responsible local authorities and energy providers prior to installation of the solar plant. You can only ensure economic success when these requirements have been taken into account. In your own interest, make sure to acquire the necessary permits from the authorities and contracts with the energy providers. We recommend that you insure your solar system against natural hazards (e.g. lightning strike).

Disclaimer

These instructions are only valid for products of the Q-Cells SE company. Q-Cells assumes no liability for damage resulting from failure to observe these instructions. Please note that the wiring and dimensioning of the plant, as well as the observance of all necessary safety regulations when laying out and installing the system are the responsibility of the installer of the plant. These instructions do not provide a basis for liability of Q-Cells SE. Q-Cells SE is only liable in the context of contractual agreements or in the context of accepted guarantees. It assumes no responsibility extending beyond the functional capability and safety of the modules. Please also observe the instructions for the other components of the solar system. It may be necessary to generate and evaluate the statics for the entire project. If your questions are not adequately addressed in these instructions, please first contact your system supplier. You can find more information at our website www.q-cells.com.

2 PRODUCT DESCRIPTION Q.SMART

TECHNICAL DATA (you can find additional data in the respectively valid data sheets at www.q-cells.com)

PRODUCT LINE	Q.SMART UF (SL1)	Q.SMART UF L (SL2)	Q.SMART (SL1-F)
Type	unframed	unframed	framed
Area [m ²]	0.75	0.94	0.76
Weight [kg]	13.2	16.5	14.5
Max. system voltage V _{sys} [V]	1000	1000	1000
Max. reverse current I _R [A]	6.5	5.0	6.5
Junction box	Protection class IP 65 with bypass diode	Protection class IP 65 with bypass diode	Protection class IP 65 with bypass diode
Connector	Multicontact MC4	Multicontact MC4	Multicontact MC4
Flammability rating	C	C	C
Wind / snow load [Pa]	2400	2400	5400
Certificates	All modules: CE, IEC 61646 (Ed. 2), IEC 61730 (Ed. 1) application class A Q.SMART Series G1.1: UL 4703		

FIGURE 1: Exterior dimensions (in mm) and components for Q.SMART UF, Q.SMART UF L and Q.SMART

Q.SMART UF

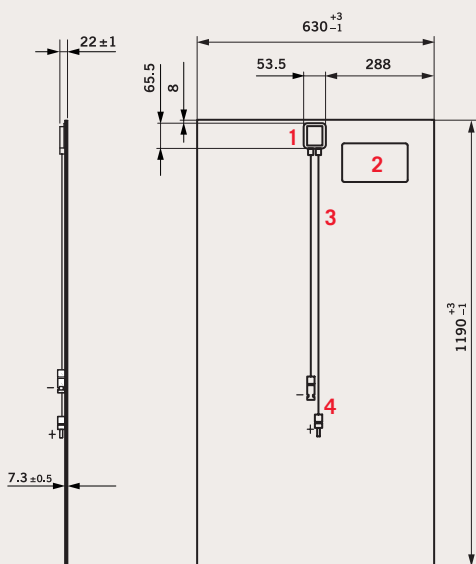

Q.SMART UF L

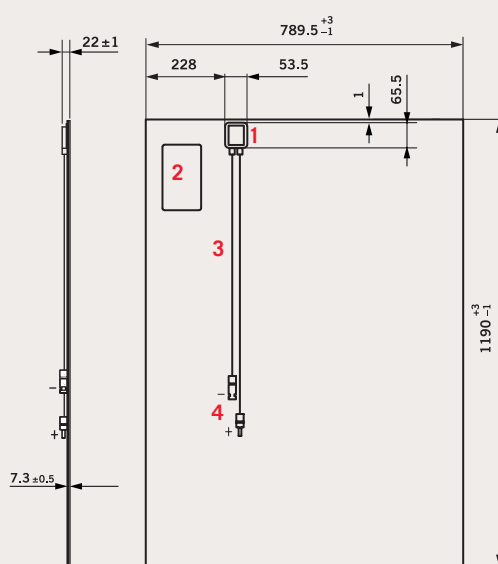

Q.SMART

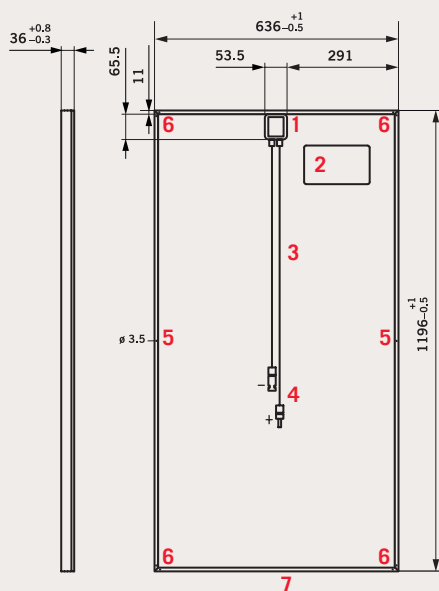

Components (rear view)

- 1 Junction box
- 2 Product label
- 3 Connection cables
G1.0: (+) 770 (+30/-0) mm, 650 (+30/-0) mm
G1.1: (+) 855 (+30/-0) mm, (-) 735 (+30/-0) mm
- 4 Connectors (with + and - polarity)
- 5 Grounding points (only Q.SMART)
- 6 Drainage holes (only Q.SMART)
- 7 Frame (only Q.SMART)

3 SAFETY INSTRUCTIONS

SAFETY INSTRUCTIONS



DANGER! Danger due to electric shock!

A solar module generates electricity and voltage even at a low intensity of illumination. Arcing can occur when contacts in a live electrical circuit are physically disconnected. This can result in grave or mortal injury. The severity increases when several modules are connected.

- Never disconnect plugs when under load. Ensure that the modules are first disconnected from the inverter prior to opening any contacts in the solar installation.
- Cover the solar modules with opaque material for the entire duration of assembly. Only then the module is reliably de-energised.
- The regulations and safety instructions for the installation of electrical devices and systems must be observed (see Chapter 3.3).
- In the case of module or phase voltages of more than 120 V ripple-free DC, the extra-low voltage range is exceeded. Undertake the necessary protection and cautionary measures.
- Do not insert electrically conductive parts into the plugs and junction box. Do not touch the contacts or exposed terminals.
- Keep children and unauthorised people away from the modules.
- In case of damaged modules or operational errors of the solar array, always contact your installer or the Q-Cells Technical Customer Service (see Chapter 6).

WARNING! Danger of injury due to broken glass! Risk of injury due to falling modules!

The modules are primarily made of glass and must therefore be handled with appropriate caution.

- In order to ensure safe mounting, orient yourself to the national regulations for work safety and accident prevention.
- Wear suitable protective clothing (e.g. safety shoes, protective gloves) in order to prevent injuries.

PRODUCT PROTECTION

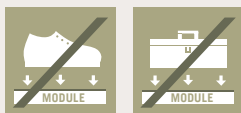

- Protect the modules against scratches and other damage, especially from impact at the edges or improper storage.
- Do not subject the module surfaces to mechanical stress. Do not stand on the modules. Do not drop or place objects on the modules.
- Only carry out modifications of the module that have been confirmed by Q-Cells in writing in advance. Do not carry out any extra drilling (e.g. for fasteners) on the solar module.
- Do not open the junction box under any circumstances.
- Do not use light concentrators (e.g. mirrors or lenses) in attempting to increase the capacity of the module. The module may be damaged. This also voids the warranty.

3.1 TRANSPORT AND STORAGE



To prevent damage of the modules:

- Store the modules securely in cool and dry rooms. The packaging is not weather-resistant!
- Transport the module in its original packaging until installation.
- Use a glass suction cup to remove and transport a module or hold the module at the edges. Carry the module vertically over longer distances.
- Do not lift or move the module using the cables or at the junction box under any circumstances!
- Do not stack the modules.
- Do not rest the module unprotected on its edges.

4 AREA OF USAGE AND INSTALLATION LOCATION

INSTALLATION LOCATION

- The modules are certified according to the norm IEC 61646 for safe operation in moderate climates.
- The permitted module temperatures lie between -40 °C and $+85\text{ °C}$. Please ensure that adequate ventilation exists below the module so that elevated module temperatures can be avoided.
- Observe the requirements for a functional grounding depending on the installation location (see Chapter 5.5 „Grounding“).
- Do not expose the modules to chemicals.
- Do not place the modules in standing water. The junction box is splash-proof only.
- Do not install the modules near highly flammable gases and vapors (e.g. gas containers) or near open flame and flammable materials. Solar modules are not explosion-proof operating equipment.
- The modules are not suitable for mobile usage or for indoor installations.

AVOIDANCE OF SHADING



Optimal solar irradiation results in a maximum energy yield. For this reason, set up the modules so that they are facing the sun.

Avoid shading of the modules, as this has a negative impact on the energy yield. A module is considered shade-free when it is entirely unshaded throughout the year (e.g. by buildings, chimneys, trees). Even partial shading of the modules (e.g. by overhead lines, dirt, snow) should be avoided (see also Chapter 7 “Cleaning and maintenance”).

Also, refer to the specifications for module orientation and tilt angle (see Chapter 5.1).

5 LAYOUT, ASSEMBLY AND INSTALLATION

SAFETY INSTRUCTIONS



WARNING! Damaged module components may cause risk of fire hazard!

- Only install undamaged solar modules.
- Ensure that the junction box, cable and connectors are undamaged prior to installation.
- Do not open the junction box under any circumstances.

- Always store the solar modules securely in a dry place. The packaging is not weather-resistant!
- The voltage of a module is higher at lower temperatures and/or higher irradiation than the Standard Test Conditions (25 °C, 1000 W/m²). This must be considered so that the overall voltage of the module strings does not exceed 1000 VDC (according to IEC 61646 / IEC 61730 standard) or 600 VDC (according to UL 1703 standard).
- Observe the requirement of functional grounding depending on the installation location (see Chapter 5.5 “Grounding”).
- Integrate the solar system in the existing lightning protection system, in accordance with the local regulations.
- Do not install or perform maintenance the modules in strong wind or rain. We recommend that mounting and installation only be performed in dry weather.
- During mounting on buildings, there is a danger that tools, mounting materials or solar modules can fall and injure people. Block off the danger area on the ground before beginning the assembly work.
- Warn people near the danger area or in the building. Keep children away from the installation site.
- Carry out wiring work in such a way that people are not endangered and that no damage can occur.
- Protect all parts of the module during transport and installation from mechanical stresses (e.g. from pressure, tension, torsional stress). Ensure that the bend radius of the connection cables is kept greater than 60 mm at all times.
- The solar modules, especially the connectors and tools, must be dry during installation.



WORK SAFETY REGULATIONS

In order to ensure safe mounting, familiarise yourself with the national regulations for work safety and accident prevention.





The regulations and safety instructions applicable for the installation of electrical devices and systems must be observed.

FIRE PROTECTION

Also observe valid regulations and safety instructions concerning the fire protection classification for rooftop installations. The module belongs to fire protection class C.

5.1 MOUNTING VARIANTS

FIGURE 2: Approved clamping areas and mounting variants for the solar modules (top view). Measures in mm. The measures refer to the distance between the module edge and the centre of the clamp.
BEWARE! The mounting variants also apply for landscape installations.

 Module
  Clamping area
  Substructure
  Substructure with rubber support

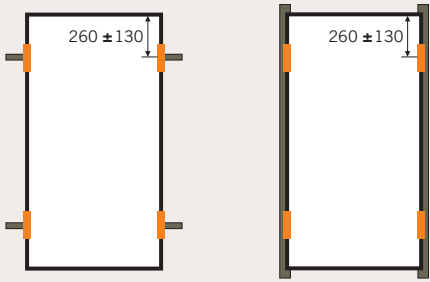
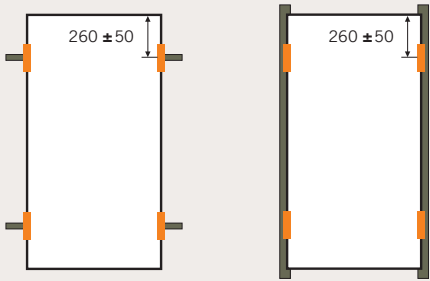
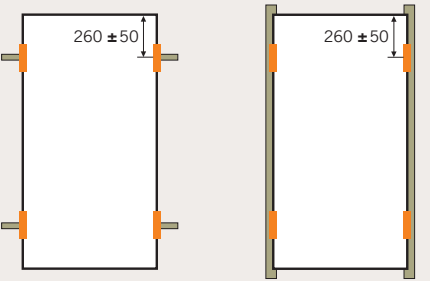
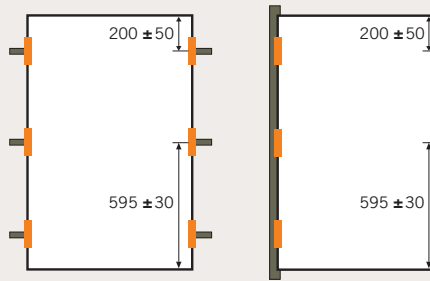
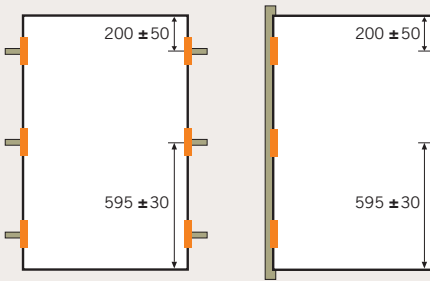
MODULE TYPE	POINT SUPPORT	LINEAR SUPPORT
Q.SMART		
Q.SMART UF		
Q.SMART UF L		

SPECIFICATIONS FOR LINEAR SUPPORT

With linear support, the modules lie along the lateral sides on the substructure. When using this mounting variant, place a silicone-free rubber support plate between the substructure and the clamps.

Only use approved clamps in accordance with Q-Cells clamp list. This list is available upon request from the Q-Cells Technical Customer Service.

MODULE ORIENTATION AND TILT ANGLE



CAUTION! Incorrect orientation of the module may cause risk of fire hazard!

- The modules may be installed in landscape or portrait format.
- Install the module in such a way that the junction box is positioned in the upper area of the module and the wires hang downwards (Figure 2).
- Ensure that the drainage openings of the frame are left open following installation to allow water runoff. This prevents frost damage.
- Install the modules with a minimum tilt angle of 3°.
- For installations with a tilt angle <math><20^\circ</math>, regularly check for dirt built up (soiling, bird droppings, etc.). Rain should help to remove soiled areas, though regular cleaning is recommended for all installations (see Chapter 7 “Cleaning and maintenance”).
- Install the module in such a way that rainwater and snowmelt can run off freely to avoid standing water or puddling.
- The optimal tilt angle of the module depends on the respective latitude. We recommend a photovoltaics simulation tool to ensure the optimal orientation.

WIND/SNOW LOAD

Unframed modules are suitable for use with wind and snow loads up to 2400 Pa.
Framed modules are suitable for use with wind and snow loads up to 5400 Pa.

MOUNTING STRUCTURE

Install the module to a mounting structure:

- that corresponds to the necessary statics and the local snow and wind loads.
- that is correctly fastened in the ground, on the roof or on the facade.
- that can transfer forces on the module to the assembly substructure.
- that ensures that no mechanical stresses (e.g. caused by vibrations, twisting or expansion) are generated on the module.
- that ensures sufficient back ventilation of the module.
- that ensures long term stability.
- that will not give rise to galvanic corrosion in case of direct metal contact (i.e. grounding lead, screws, washers, etc.)
- that allows for strain-free expansion and contraction due to natural ambient temperature variations.

Clamps and rail system must be constructed as a coordinated unit.

MODULE FASTENING

To ensure a long-term stability of the solar modules:

- Install the module according to the mounting variants and the defined clamp areas in Figure 2.
- Ensure that the module cannot bend or twist more than 3 mm/m (without additional load such as wind, snow, etc.). Observe the technical rules for point or linear supported glazing.
- Position the module planar.
- Install the modules with a minimum distance of 10 mm to each other.
- Use all fastening points and avoid direct contact between the glass and metal (e.g. mounting rails).
- Ensure, that the rubber support of the mounting structure rest solidly and do not shift.
- Depending upon the local wind and snow load, and the angle of inclination, we recommend attaching non-slip safeguards to and spacers between the modules. This accounts for portrait format installations in particular.

5.2 MECHANICAL ASSEMBLY - UNFRAMED MODULES

CLAMP SYSTEMS

Only install clamp systems approved by Q-Cells. Failure to do so will void the warranty. This list is available upon request from the Q-Cells Technical Customer Service. Upon request, Q-Cells can test clamp systems for approved use.

GENERAL REQUIREMENTS FOR FASTENING THE CLAMP SYSTEM:

- Ensure that the threaded connections do not generate extra stress on the module. The modules are positioned “floating”.
- Don't attach the metal clamps directly to the glass. Use a suitable, silicone-free rubber support between the module and the substructure or clamps.
- Adjust the clamp height to the module thickness.
- Ensure that the clamps have a width of ≥ 70 mm.
- Ensure that the clamps do not throw shadows onto the active cells. The distance from the glass edge to the first active cell is 18.5 mm (Figure 3).
- Ensure that clamps overlap the glass edge (Figure 3):
 - 10 mm to 15 mm on the top side of the module
 - ≥ 12 mm on the module underside
- Ensure a minimum gap of > 1 mm between the glass edge and inner side of the clamp at 25 °C (Figure 3) to allow for thermal expansion of the module.

FIGURE 3: Clamp overlap of glass edge on the module top side (10-15 mm) and module underside (≥ 12 mm), distance between glass edge and inner side of clamps (> 1 mm)

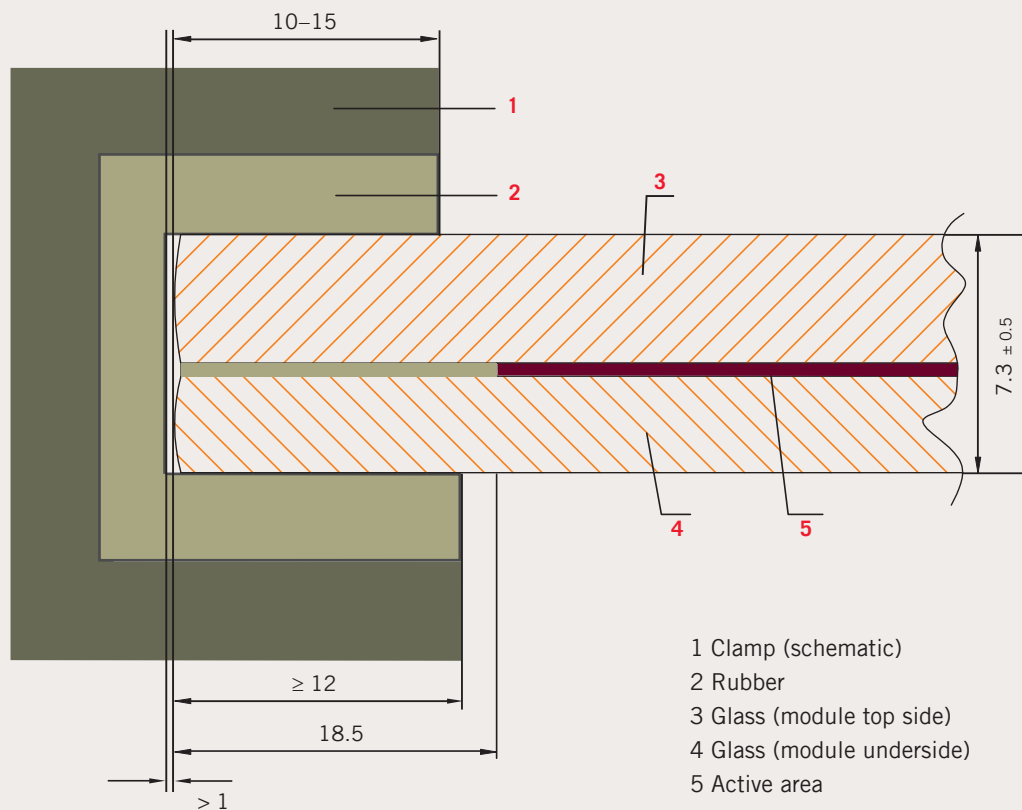

5.3 MECHANICAL MOUNTING - FRAMED MODULES

CLAMP SYSTEMS

Fasten the module with 4 clamps each and a recommended torque of 18 Nm to the rails. If the information of the clamp manufacturer differs from this recommendation, the values of the clamp manufacturer are to be used.

You can see the defined clamp areas in Figure 2 (Chapter 5.1).

The framed module Q.SMART can be installed with commonly available clamp systems that satisfy the following conditions.

GENERAL REQUIREMENTS OF THE CLAMP SYSTEM:

- Clamp width: ≥ 60 mm
- Clamp height corresponding to 36 mm frame height (Figure 4)
- Clamp depth: 7 -12 mm (Figure 4)
- Clamp area (clamp depth x clamp width): ≥ 600 mm²
- Clamps that comply to the local statics requirements
- Clamps that ensure longevity and secure, long-term fastening of the modules

FIGURE 4: Frame profile with clamp height and depth in mm.

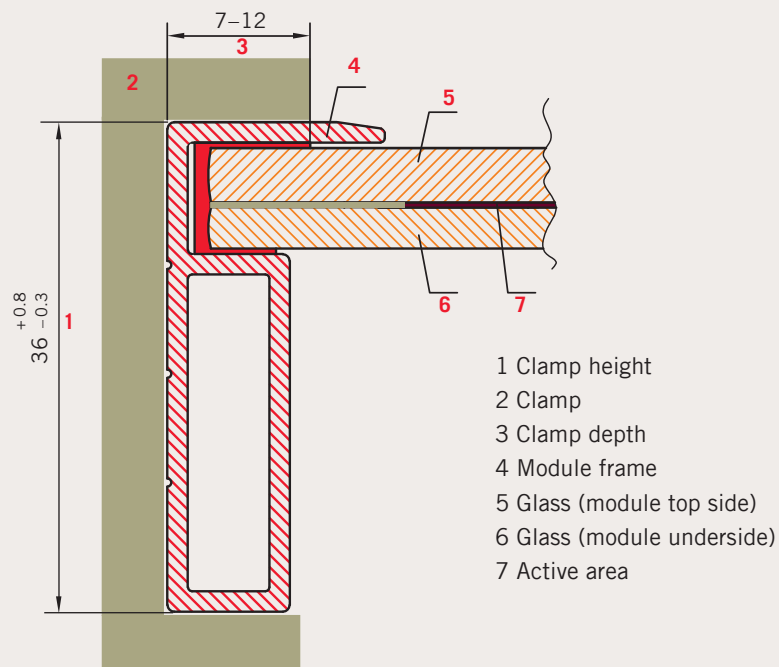

5.4 ELECTRICAL LAYOUT

YOU CAN FIND THE DETAILED ELECTRICAL PARAMETERS IN THE PRODUCT DATA SHEET.

MODULE SELECTION

Only connect modules of the same type and the same power class. This is the only way to achieve optimal yields.

SAFETY FACTOR

It may occur during normal operation that the module provides a greater current and / or a higher voltage than that determined under standardized test conditions. You should therefore include a safety factor of 1.25 for:

- the determination of the voltage measurement values (V_{oc}) of components,
- the determination of the current measurement values (I_{sc}) of conductors,
- the determination of fuse sizes and
- the measurement of control systems connected to the output of solar modules.

Alternatively, the respectively valid national regulations for the installation of electrical systems are to be used.

SERIES CONNECTION

- Only connect modules of the same power class. Pay special attention to the positive sorting given in the data sheet and the tolerance ranges for V_{oc} and V_{mpp} .
- A series connection of modules is only permitted up to the maximum system voltage specified in the respective data sheet revision.
- Carry out the layout taking into account all working conditions and relevant technical regulations and standards. In this way you ensure that the maximum system voltage, including the necessary safety supplements are not exceeded.
- Also take the voltage limitation of the inverter into account when laying out the string length.

REVERSE CURRENT

Only connect modules of the same type and voltage class.

Do not exceed the maximum permissible reverse current as given in the respective data sheet. In the event of reverse currents (caused by module defects, ground leakage or shading), modules can be placed under strain.

In order to safely account for reverse currents, we recommend the following fuse variants:

1) LAYOUT WITH LIMITATION OF THE NUMBER OF PARALLEL CONNECTED STRINGS: Without further measures for current limitation, only a maximum of 4 strings of modules may be operated parallel on an inverter or on a MPP tracker.

2) LAYOUT WITH STRING DIODES: When more than 4 strings are connected parallel, a maximum of 4 strings respectively must be protected against reverse currents from the remaining system with a shared string diode.

3) LAYOUT WITH STRING FUSES: In this case, each string of modules must be protected with 2 A on the plus and minus sides.

BEWARE! When installing modules from different product revisions, comply to the minimum permissible limitation of the product revisions used.

INVERTER

The choice of inverter depends on the country of the installation (see table 1):

- in countries where functional grounding is required as well as within 500 m from the coastline: inverter with galvanically isolated transformers must be used
- in countries where functional is not required: inverters with or without transformers can be used.

Irrespective of the installation country, please follow the instructions for the use of inverters with transformers as provided in the following section „Functional grounding.“ Also, refer to the specification and instructions as provided by the inverter manufacturer.

5.5 GROUNDING

FUNCTIONAL GROUNDING



Install a functional grounding to the DC side of the solar array, when:

- you install in a country where functional grounding is required according to table 1.
- you install within 500 m from the coastline.

WARNING! Incorrect grounding may cause risk of fire hazard!

Direct grounding with a direct connection of pole and earth is prohibited.

Ensure that the following requirements for a functional grounding are met:

- a maximum of 50 module strings in the module array connected to the inverter,
- the negative pole of the solar module array is to be connected to ground **and**
- the current through this ground connection must be limited to 20 mA in order to protect the system from ground leakage current in the case of isolation failures (e.g. in case of module glass breakage). One possibility to achieve this current limitation is by installing a ≥ 50 kOhm resistor (considering 1000 VDC max system voltage) between the negative pole and ground. Make sure to use a resistor of the appropriate power class ($P=U^2/R$).
- only inverters are used for which the manufacturer provides a ground kit complying with the above provisions.

TABLE 1: Countries where functional grounding is required

• Albania	• Greece	• Montenegro	• Slovenia
• Andorra	• Hungary	• Portugal	• Spain
• Bosnia and Herzegovina	• Italy	• Romania	• Turkey
• Bulgaria	• Kazakhstan	• Russia	• Ukraine
• Croatia	• Macedonia	• Switzerland	• Vatican City
• France	• Moldova	• San Marino	
	• Monaco	• Serbia	

SAFETY BONDING

Ground each of the framed modules with Parker screws (according to DIN 7981, material: A2, size: 4.2 mm x 16 mm) to the grounding points indicated in Figure 1. Attach the screw as shown in Figure 5.

FIGURE 5: Attachment of the grounding

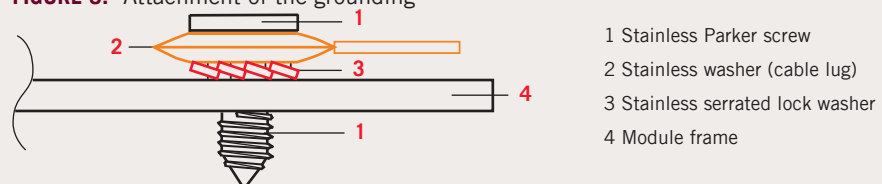

5.5 ELECTRICAL INSTALLATION

SAFETY INSTRUCTIONS



DANGER! Life danger due to electric shock!

When disconnecting a DC circuit, electric arcs can occur that can result in dangerous injuries.

- Carry out work on the inverter and the electrical cables with extreme caution.
- Never disconnect the plug when under load.
- Ensure that the modules are disconnected at the inverter prior to disconnection from one another.
- Be absolutely certain to observe the time intervals specified by the manufacturer after switching off the inverter and prior to starting subsequent work such that the energised components can be discharged.
- Cover the module for the duration of the assembly with opaque material. Only then is the module reliably de-energised.
- Never touch live contacts with your bare hands. Use only insulated, dry tools for the installation.
- Pay attention to the correct polarity when connecting. The connectors are labelled with plus for the positive terminal and minus for the negative terminal.
- Do not open the junction box under any circumstances. The bypass diode must not be removed.

ELECTRICAL CABLES AND CONNECTORS

Observe the following when selecting and using electrical cables and connectors:

- Only use solar cables and insulated, identical connectors.
- Ensure that all electrical components are in a undamaged, dry and safe condition. In this way you avoid that electrical short-circuits or dangerous contact voltages occur due to defective or damaged cables.
- Always avoid the mechanical stressing of the electrical cables.
- Ensure a tight connection between the individual connectors (especially to the inverter). Make sure they click together properly.

AFTER COMPLETION OF INSTALLATION

Upon completion of the installation, ensure that:

- the wiring is protected from dirt and moisture.
- the plug connections do not lie on a water-channeling surface and are properly connected.
- all necessary safety and functional tests have been carried out according to the current state of technology.

6 TROUBLESHOOTING



DANGER! Life danger due to electric shock! Damaged module components may cause risk of fire hazard!

- Please do not attempt to correct problems on your own!
- In case of problems or damaged modules (e.g. glass breakage, damaged cables) please contact your installer immediately. The installer must ensure that the module is removed from the system as soon as possible.

7 CLEANING AND MAINTENANCE

Q-Cells CIGS modules are built to last and require minimal maintenance. Light dirt is typically washed away by rain. However, rain may not adequately clear more stubborn grime (i.e. pollen, vegetation, bird droppings, etc.). Such soiling which shades the active area of the module can lead to a reduction in the system's performance.

SAFETY INSTRUCTIONS



WARNING! Danger of injury from heated and live modules!

Only clean the modules when the module temperature lies between 10 °C and 30 °C, e.g. in the early morning or late evening. Do not wear electrically conductive parts.

WARNING! Risk of falling during maintenance of roof installations and building-integrated installations!

Never enter the installation area alone and unsecured. We recommend commissioning a specialist company to perform this work. Consult your installer on location.

CLEANING



As the operator, you should regularly remove dirt built up from the modules. In addition to the safety instructions and chapter 3, observe the following points:

- Never step on the modules. Do not subject the modules to mechanical stress.
- Avoid cleaning with water when there is a danger of frost and strong temperature differences between the module, water and air.
- Hard water used as a cleaning agent should be decalcified beforehand in order to avoid water staining. Remove any standing water from the module.
- Do not use abrasive detergents or surface-active agents (e.g. soap). Do not scratch dirt off. This can damage the surface of the module.

Only remove snow and ice without exerting force (e.g. with a broom).

Proceed as follows to remove dirt from the **top of the module**:

1. Rinse coarse dirt (dust, leaves, etc.) from the module with lukewarm water.
2. Moisten stubborn stains and remove them carefully.

Use lukewarm water and a soft cloth or sponge. If necessary, it is possible to use isopropanol (IPA) **selectively**. Follow the safety instructions on the IPA packaging. Ensure that the IPA does not run off between the module and the frame or into the module edges.

Free the **substructure** of dirt (leaves, bird nests, etc.). In the case of ground-mounted installations, we recommend regularly trimming of the vegetation order to avoid partial shading. Be sure to pay attention to the cables and stones.

MAINTENANCE

The solar system should be inspected annually by a specialist installer for:

- secure fastening and corrosion-free system components
- secure connection, cleanliness and integrity of all electrical components
- the contact resistances of the grounding.

8 DECOMMISSIONING AND RECYCLING



Do not decommission the module on your own. Commission a specialist company for this purpose. Q-Cells is a member of the European PV Cycle Association and accepts our product responsibility. You can give back modules of Q-Cells SE and allow them to be processed within the PV Cycle member states. More information can be found at www.pvcycle.com.

CONTACT

Q-CELLS SE

OT Thalheim
Sonnenallee 17-21
06766 Bitterfeld-Wolfen
Germany

TEL +49 (0)3494 66 99-0
FAX +49 (0)3494 66 99-199
EMAIL service@q-cells.com
WEB www.q-cells.com